

Component 4: Introduction to Information and Computer Science

Unit 3: Computer Hardware & Architecture

BMI540/640
Week 1

Unit Objectives

- List the major elements of a computer (motherboard, CPU, I/O devices, memory, secondary storage, buses, expansion cards, ports, etc.).
- Describe how data is stored in memory and in secondary storage.
- Describe how data is represented in binary.
- Describe the function of the CPU.
- Describe how data is input/output from the computer.
- Describe how a computer system works together.
- Introduce specialized architectures and embedded systems used in healthcare settings.

Component 4/Unit 3

Health IT Workforce Curriculum
Version 1.0/Fall 2010

2

Data is Stored in Types

- Data type determines how data is stored in memory.
- Data is interpreted by software based on its type.
- Types of data
 - Integer numbers, e.g. 12
 - Floating point numbers, e.g. 3.453
 - Characters, e.g. 'a'

Component 4/Unit 3

Health IT Workforce Curriculum
Version 1.0/Fall 2010

3

Data Type Storage

- Integers are stored as binary numbers
 - Use something called "two's complement" that allows for the storage of negative and positive integers
- Floating point numbers are stored in floating point notation, which is similar to scientific notation
 - Still stored in binary
 - Exponent and mantissa are stored in binary
- Characters are stored in ASCII or Unicode
 - Each character is represented by a binary value (code)

Component 4/Unit 3

Health IT Workforce Curriculum
Version 1.0/Fall 2010

4

Storage for Characters

- The American Standard Code for Information Interchange (ASCII) was created to map (or encode) a set of 8-bit words to English language characters.
- The 8-bit word "01000001" is mapped to the English language alphabet character "A".
 - Notice this is the uppercase letter "A" not the lowercase letter "a", which is mapped to the 8-bit binary word "01100001".

Component 4/Unit 3

Health IT Workforce Curriculum
Version 1.0/Fall 2010

5

Data Addressing

- When data is stored in primary or secondary storage, each piece of data is provided a hexadecimal physical memory address by the CPU.
- Whenever data is subsequently used by a program (for example, to open or save a file) or device (for example, a print request from the user), this physical address is used as its reference.
- File addresses start with the first character of the file and end with the file's last character. Characters are strung together like the railroad cars that make up a train. Each car knows its head and tail.

Component 4/Unit 3

Health IT Workforce Curriculum
Version 1.0/Fall 2010

6

Data Addressing Example

Memory Address	Memory Contents
000	1001 (17)
001	
010	
011	
100	
101	0100 (8)
010	
111	

Component 4/Unit 3 Health IT Workforce Curriculum Version 1.0/Fall 2010 7

What is the CPU?

- The most important computer component is the Central Processing Unit (CPU).
- The CPU is the "brain" of the computer that is responsible for the main operations of the entire computer system.
 - Has its own memory: RAM (SDRAM). Modern motherboards support multiple processors (or cores).
 - The term "core" refers to all CPU components such as the ALU, control unit, and SDRAM.
 - For example, the AMD HDT90ZFBGRBOX Phenom II 1090T Six Core processor is six CPUs in one boxed unit.

Component 4/Unit 3 Health IT Workforce Curriculum Version 1.0/Fall 2010 8

CPU Functionality

- The main function of the CPU is to execute instructions.
 - Arithmetic instructions (addition, subtraction, multiplication, division, etc.).
 - Load/store instructions (get values from memory/store values in memory).
 - Branch instructions (go to another part of the program).

Component 4/Unit 3 Health IT Workforce Curriculum Version 1.0/Fall 2010 9

CPU Components

1. Arithmetic/Logic Unit (ALU)
 - a) Performs arithmetic operations.
 - b) Operands are stored in registers.
 - c) Some CPUs contain more than one ALU so that more than one math operation can be done at a time.
2. Control Unit
 - a) Manages all of the things being done by the processor.
 - b) Fetches the next instruction and decodes it.
3. Registers
 - a) Fast, temporary storage.
 - b) Connected to ALU and Memory.

CPU Components

4. Memory
 - a) Super fast RAM reserved for use by the processor.
5. Buses
 - a) Carries data between CPU components.

CPU Execution

The CPU executes instructions one at a time and is never idle

1. CPU fetches an instruction from memory.
 - Keeps track of the location of current instruction in the program counter.
2. CPU decodes the instruction.
3. CPU executes the instruction.
4. CPU writes back the result.
5. Return to Step 1.

Note: These five steps make up one instruction cycle!

CPU Components

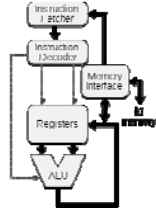

Computer Diagram

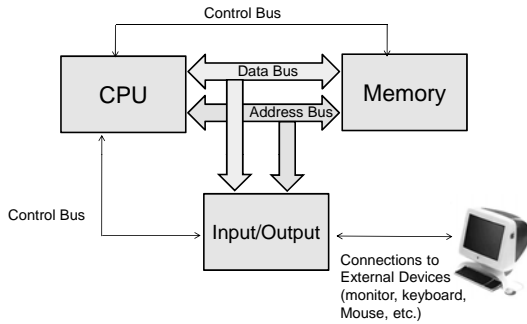

CPU Performance

- The CPU improves its performance through creation of processes and threads.
- A process is a running program, such as Microsoft Word.
- A thread is a specific task running within a process.
 - For example, Word may save changes to a file and subsequently print that file.
 - Each of these operations represents a thread within Word's process.
- Threads can exist in a number of states at any given time.
 - For example, a thread may be running, waiting, stopped, or blocked (there are more states, these are examples).

CPU Performance (cont'd)

- If a thread might be blocked because it represents a request to print something and the printer is currently in use:
 - The CPU then passes its attention to another process/thread and waits for the blocked thread to interrupt it for execution (in which case the blocked thread enters the resume state).
 - This process gives the appearance that the CPU is performing more than one operation at a time, when in fact, it is not.

The Evolving CPU

- Modern motherboards support multiple CPUs (cores) housed within one physical CPU.
- Some motherboards support installation of multiple physical CPUs on a single motherboard (as mentioned previously), each containing more than one core.
- This is an evolving technology as CPU vendors such as AMD and Intel work to produce more efficient CPUs without significantly changing motherboard architecture.

Data vs. Information

- Data is information stored on a computer a binary format.
- Recall that each character (pixel, or other object) is represented by 8-bits (or 1-byte) when it is operated on or stored by the CPU.
 - This is the definition of data.
- Information is not the same thing as data!
 - Data has no meaning or value since data is a number, character, etc.
 - Information is data presented so that it has meaning.
 - For example, the capital letter U is meaningless. However, when this piece of data is presented as a string of text in the format of "United States of America", it becomes information and has meaning.

Putting it All Together

- A computer system is made up of the hardware (including the CPU, RAM, and I/O devices) and operating system (OS) software installed on a computer.
 - Examples of devices that contain an OS include cell phones, PDAs, robots/robotic devices, routers, switches, laptops, and computers (desktops, servers, and Web servers).
- An OS is made up of thousands of computer programs that securely manage how hardware interacts with non OS – or “application” – software installed on the computer.
 - Google Earth is application software, which is a free program that a user can install on a computer.
 - Microsoft Word is a commercial application in the Microsoft Office suite of programs.

Specialized Health Care CPUs

- Medical imaging done in CT and MRI scans require specialized architectures.
- The GE Healthcare CT750 HD computed tomography scanner scans and stores hundreds of terabytes of data.
 - This type of equipment, which features Intel’s Intel Xeon-based SGI Altix UV CPU, must discern “the soft tissue and organs at almost a molecular level” and do so in real-time.
- Desktop and server CPUs cannot provide this type of performance.

Unit Summary

- In this unit, you learned:
 - The major elements of a computer include the CPU, I/O devices, memory, buses, and ports.
 - System components include the motherboard, CPU, motherboard slots, and expansion ports.
 - A computer is made up of hardware and software.
 - Computers only understand binary numbers.
 - The motherboard is made up of copper wires, known as buses.

Unit Summary

- The motherboard buses are the address, control, and data buses.
- Input/Output port types include the mouse, keyboard, monitor, USB, and other ports.
- Storage devices can be internal or external and include hard disk drives and RAM.
- Input devices include the keyboard, mouse, MRI device, CT scanner, and others.

Unit Summary (cont'd)

- Output devices include the monitor, printers, flash drives, ultrasound images, voice synthesizers, and other devices.
- Data stored in RAM is volatile.
- Data stored on a HDD is non-volatile.
- Data is stored in electronic, binary format.
- Binary numbers are either on or off.

Unit Summary (cont'd)

- The most important component in a computer is the CPU and it is made up of an ALU, control unit, and SDRAM.
- The CPU operates by use of instruction cycles.
- The CPU improves its performance through the use of processes and threads.
- Data is different than information.

Unit Summary (cont'd)

- Health care equipment requires the use of special architecture:
 - Special CPUs are required to process, analyze, and store the large amount of data created via 3-D scanners and other medical equipment.
